



15F2930

## B737 (600-900 & Max) Towbar



### Building Quality Ground Support Products Since 1961

- 8" x 15' high strength aluminum tube
  - Safety lock system to avoid separation from aircraft
  - Fully retractable hydraulic running gear for adjustable height
  - Durable powder coated paint
  - Quality shear bolts for aircraft protection
  - Extra set of shear bolts included
  - Solid tires
- Optional:
- Pneumatic tires
  - Foam filled tires

# CLYDE

Clyde Machines  
P.O. Box 194  
1150 Hwy 55 N.  
Glenwood, MN 56334 USA  
(320) 634-4504  
(320) 634-4506 Fax

[www.clydemachines.com](http://www.clydemachines.com)

# 15F2930

## B737 (600-900 & Max) Towbar

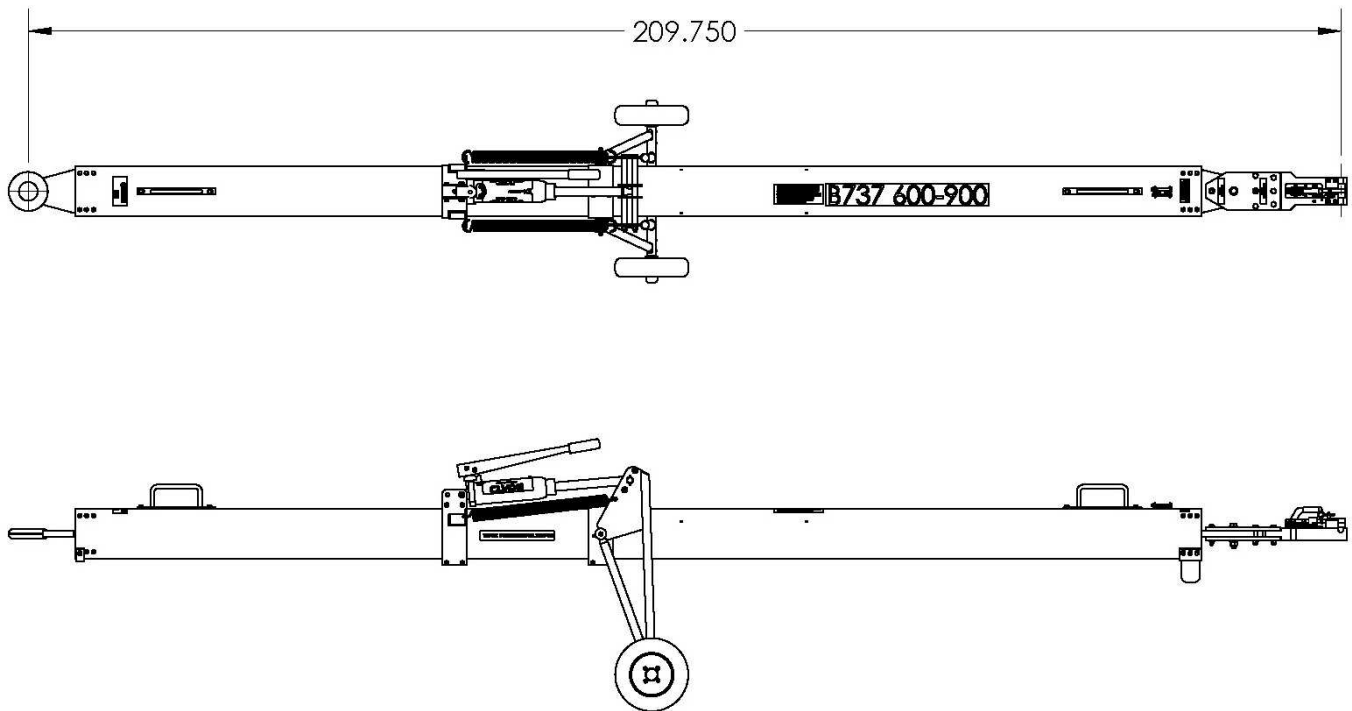

### Shipping Information

- Shipping Dimensions:
  - Weight - 350 lbs
  - Length - 212"
  - Width - 29"
  - Height - 25"
- Crated Shipping Dimensions
  - Weight - 730 lbs
  - Length - 217"
  - Width - 26"
  - Height - 27"

# CLYDE

Clyde Machines  
P.O. Box 194  
1150 Hwy 55 N.  
Glenwood, MN 56334 USA  
(320) 634-4504  
(320) 634-4506 Fax

[www.clydemachines.com](http://www.clydemachines.com)